

Arrotoloio di P. D'Auria

<http://www.origamidauria.it>

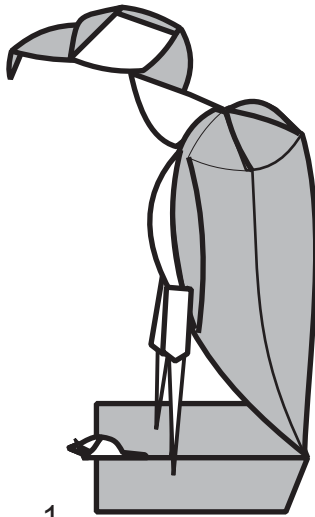

1

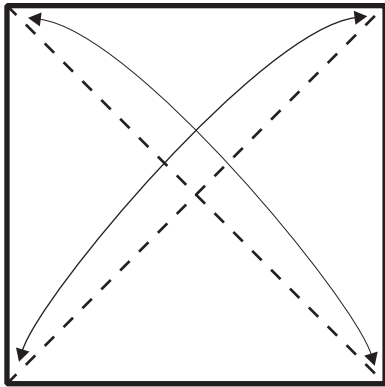

2

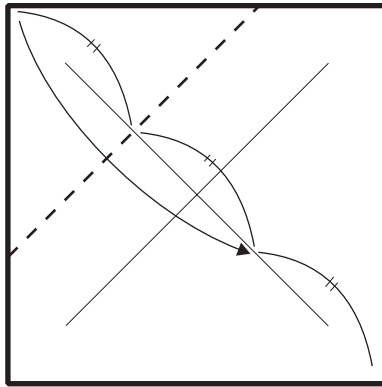

3

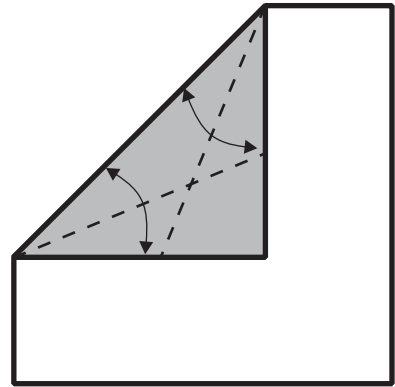

4

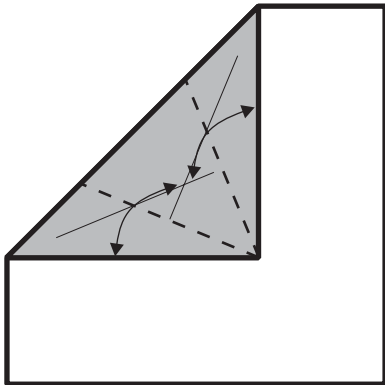

5

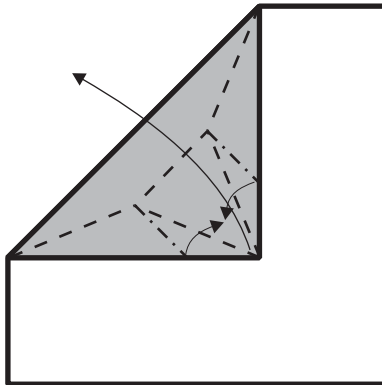

6

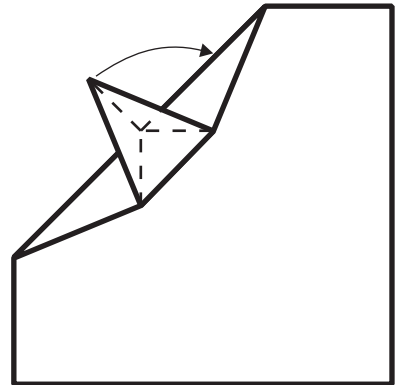

7

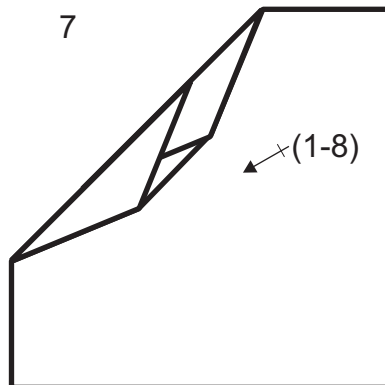

8

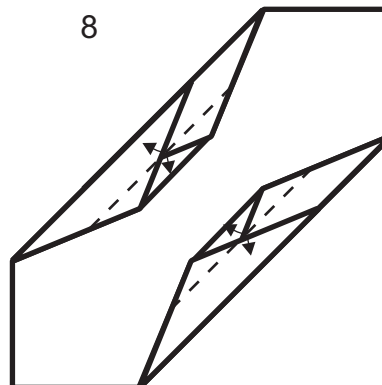

9

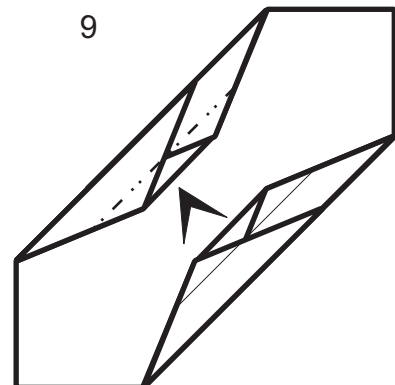

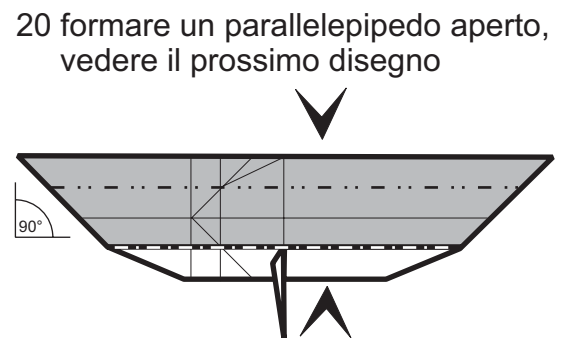
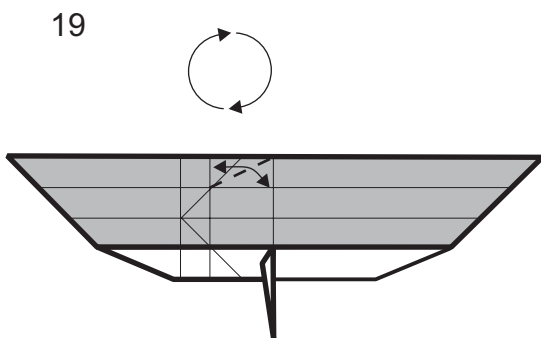
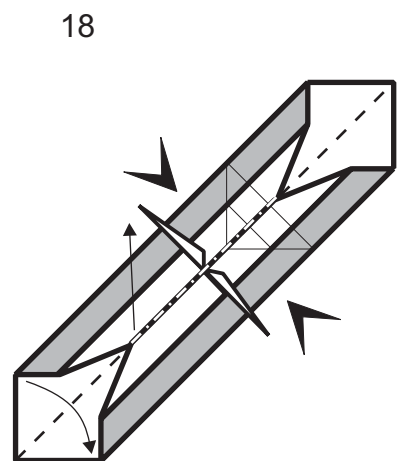
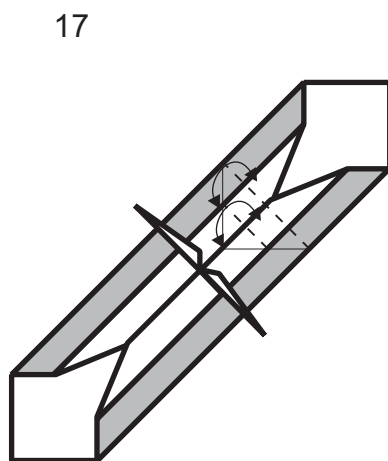
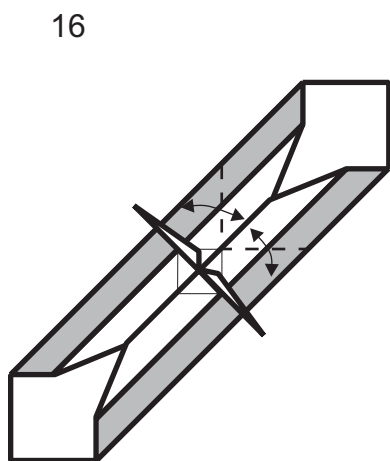
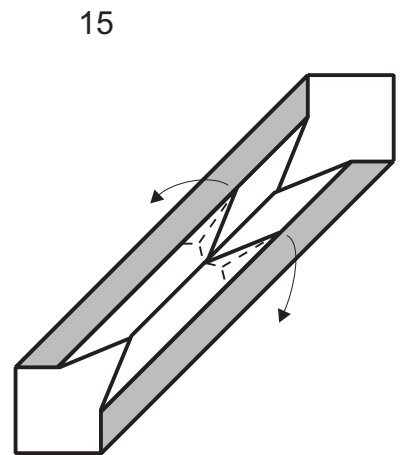
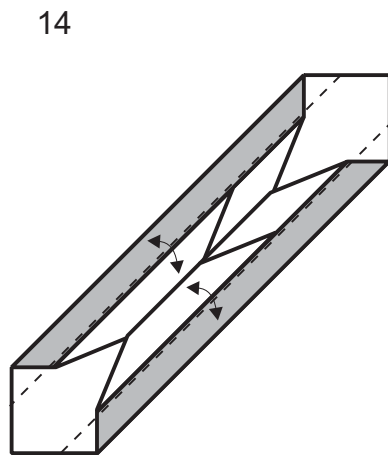
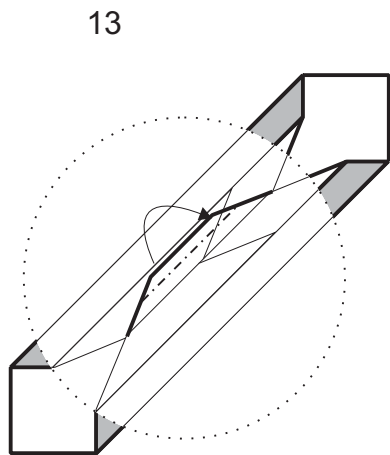
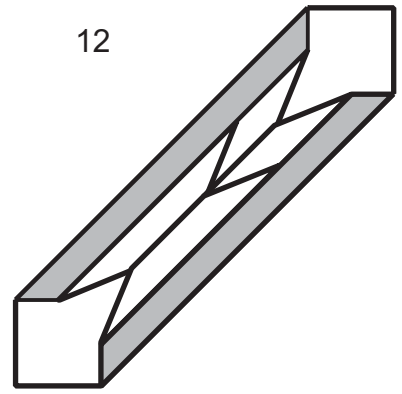
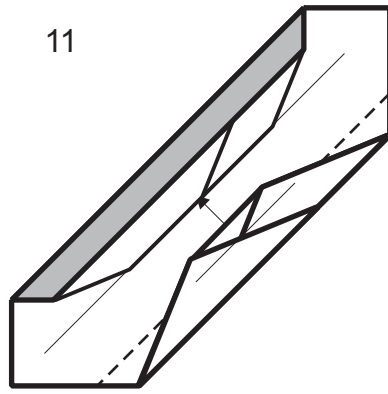
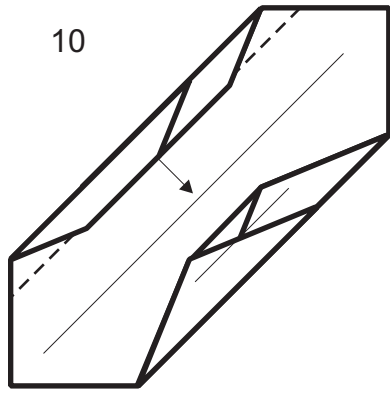

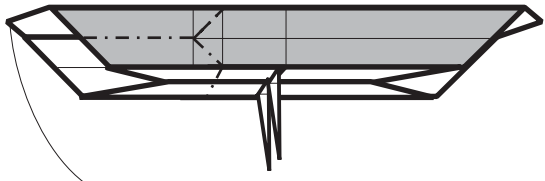

21

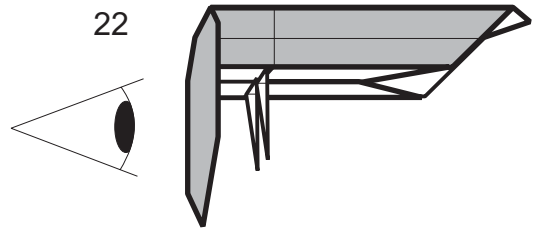

22

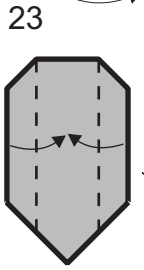

23

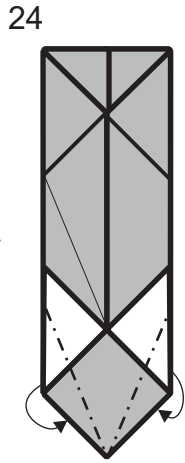

24

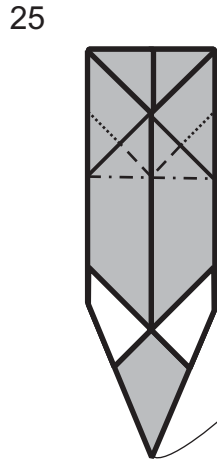

25

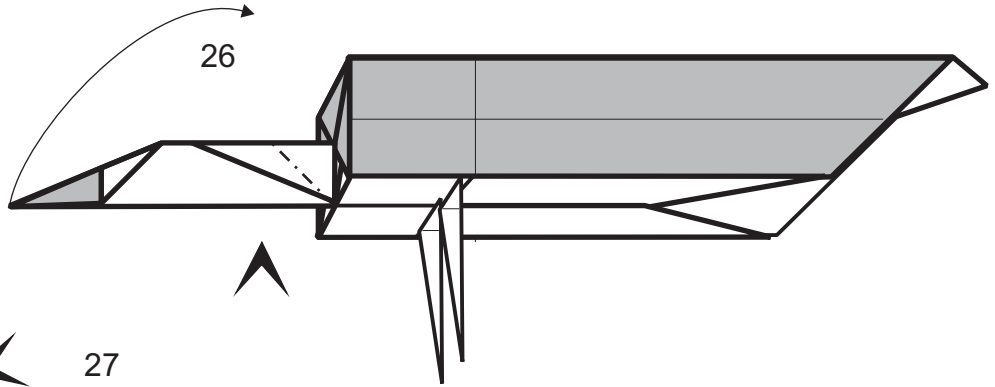

26

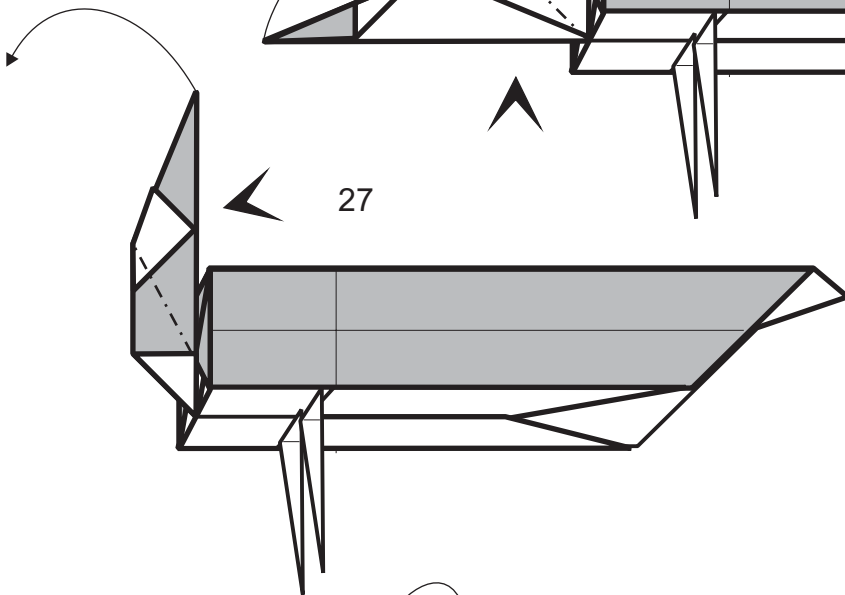

27

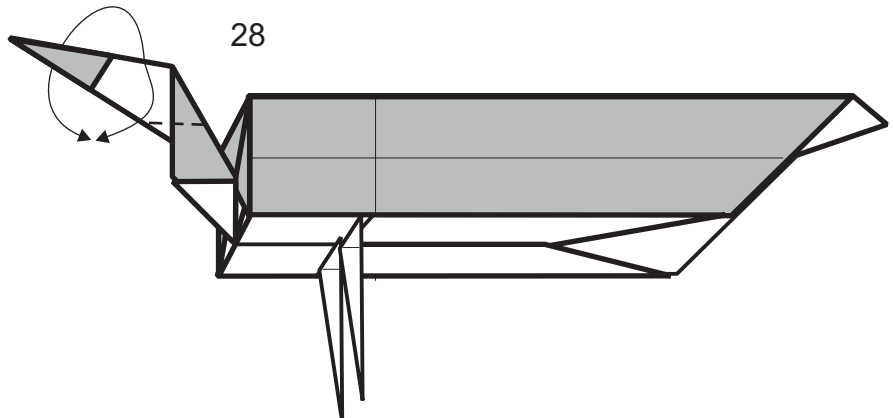

28

29

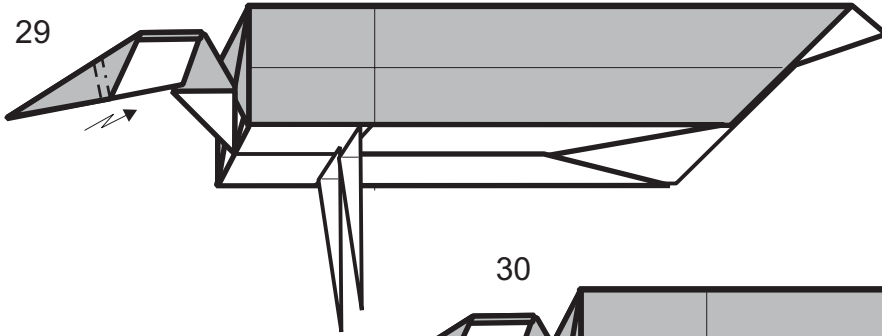

30

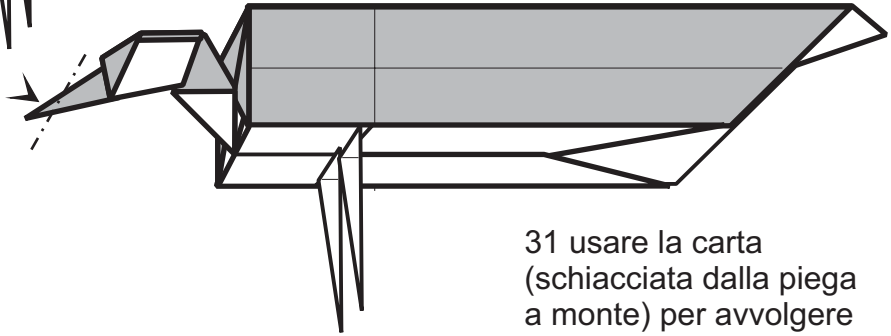

31 usare la carta
(schiacciata dalla piega
a monte) per avvolgere
il corpo come se fossero
le ali, e poi riunirla sotto
per preparare la coda,
cambiare
l'angolazione della testa.

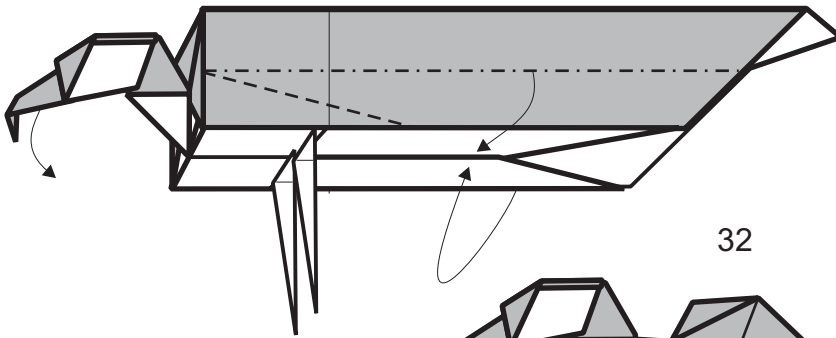

32

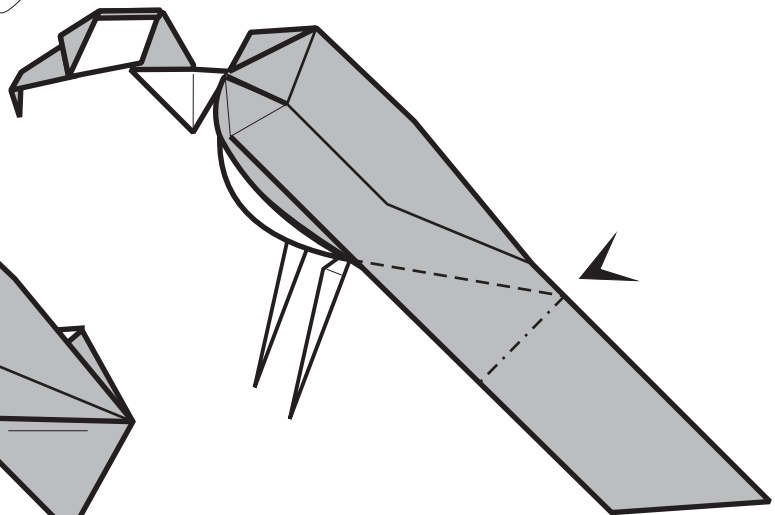

33

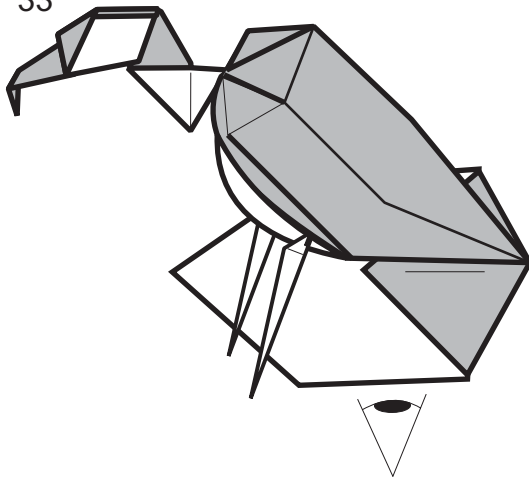

34 vista semplificata

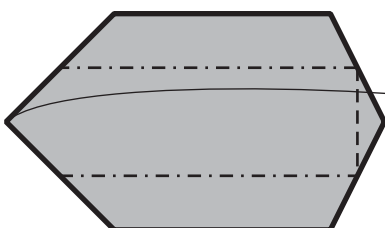

35

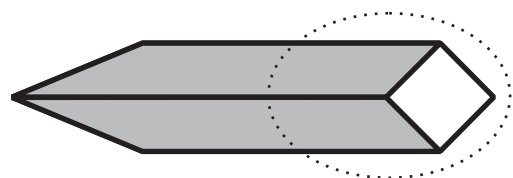

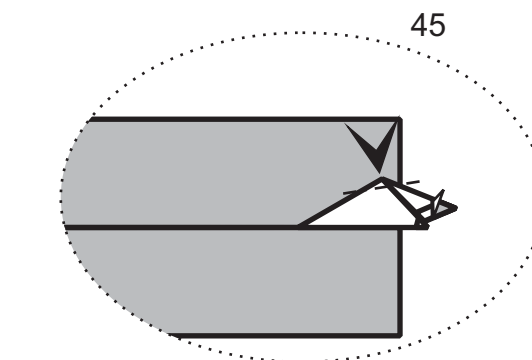
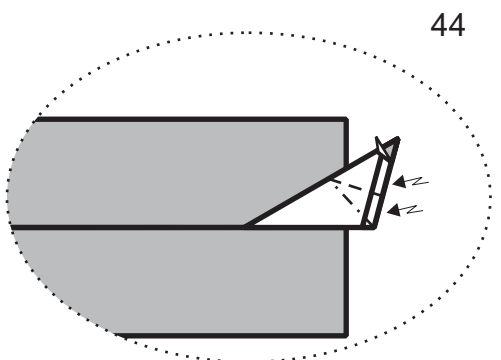
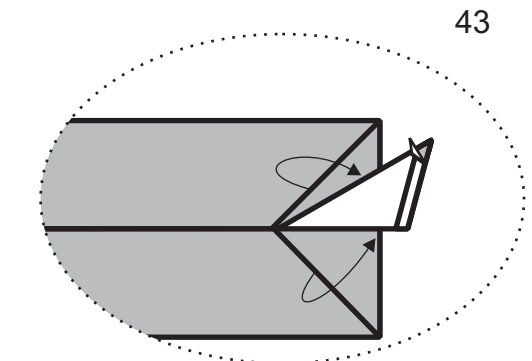
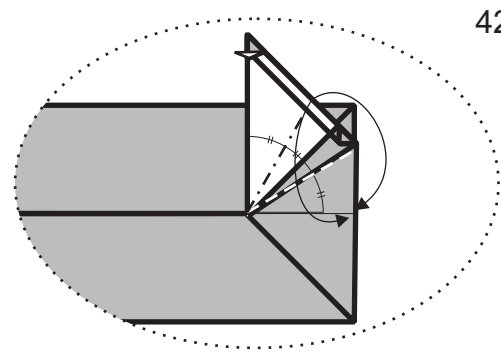
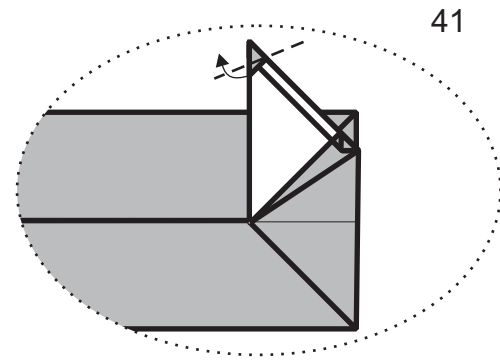
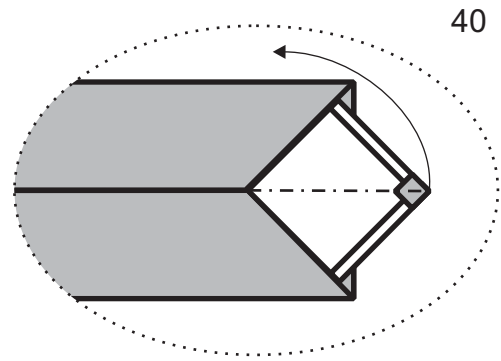
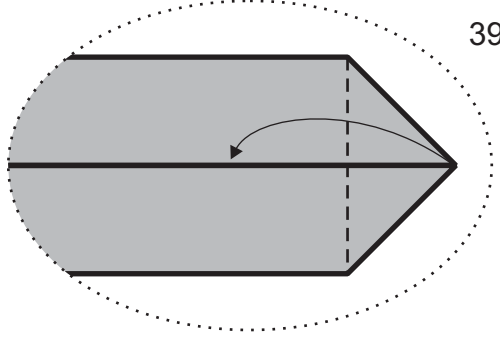
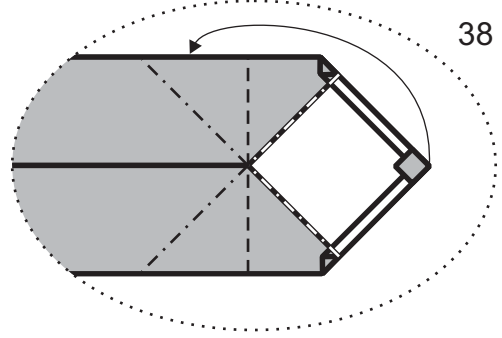
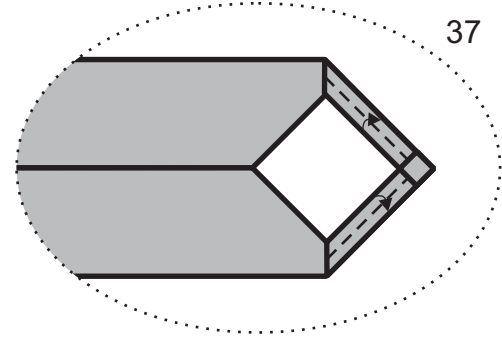
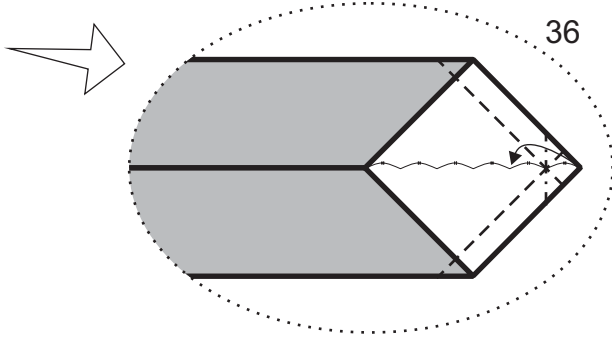

46

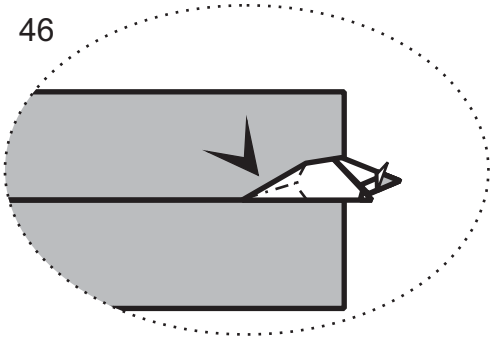

47 modellare

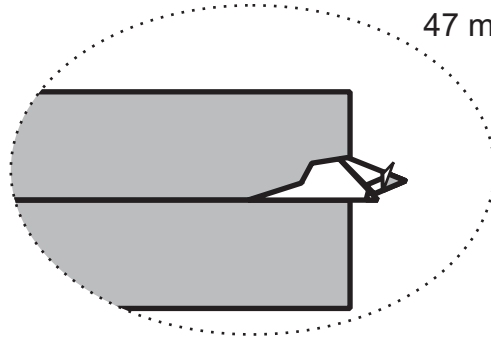

48

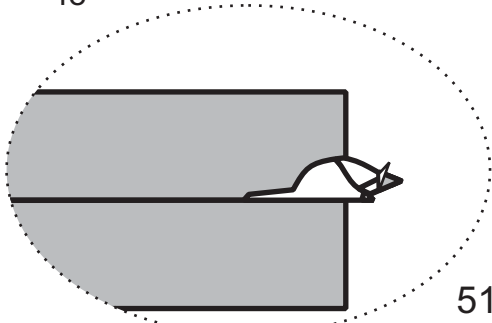

49

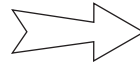
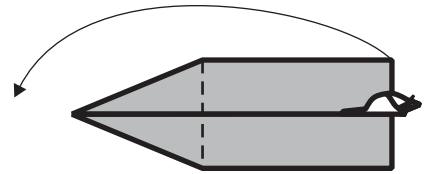

51 portare le zampe dell'avvoltoio dietro la coda del topo.

52 modellare, guardando qualche foto cercando di creare una postura più naturale possibile.

50 vista normale, aprire la parte superiore della zampa

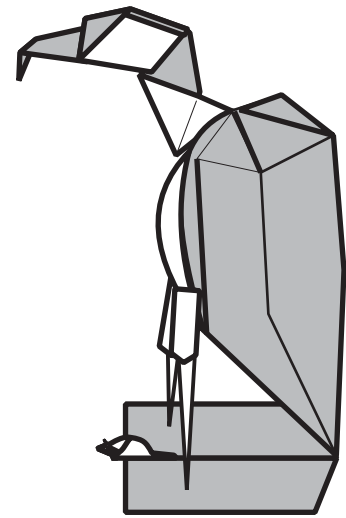
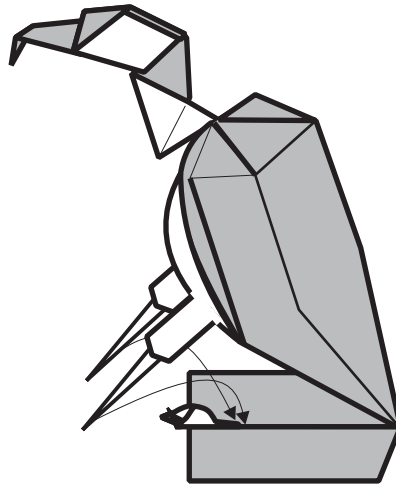
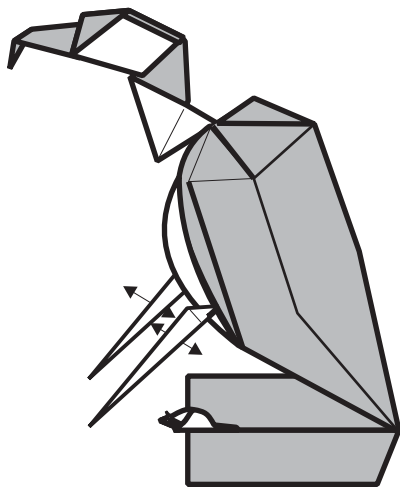

53

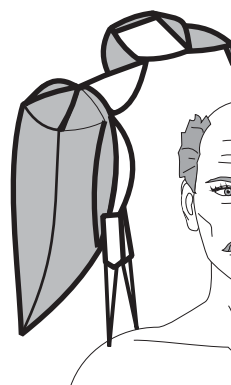
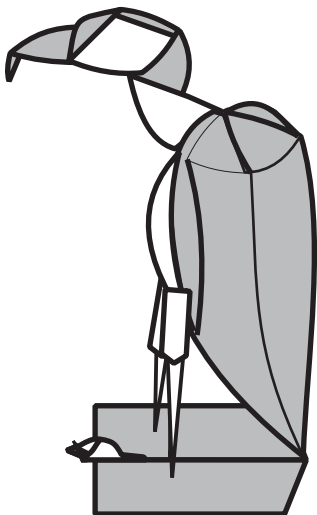

ho un po di ansia!!